



Installation Instructions

Short-Shifter for MX-5 NC – 5 gear

NC0-7000

11.2016

Remove the shiftknob and uninstall the centre console by loosening and removing the 5 screws that hold it in position.

(picture 1)

Remove the insulation material.

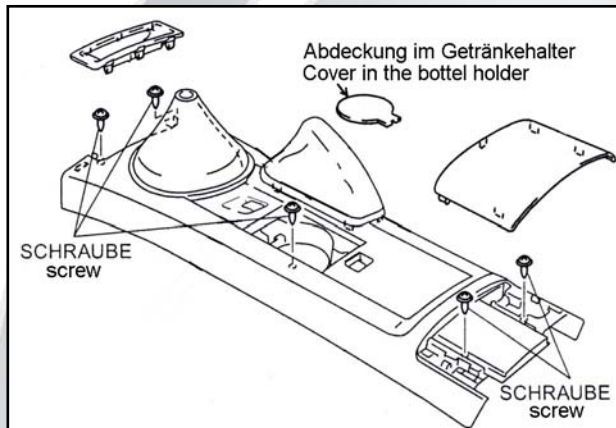

picture 1

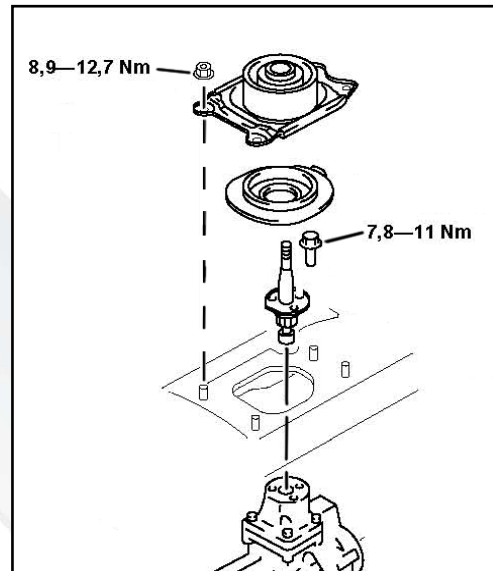

picture 2

You should see the large shift boot, that can be released by loosening the 4 screws that hold it in position. Under the large shiftboot you will find a small shiftboot, loosen the 3 screws that hold it down, and remove the complete assembly (large shiftboot, small shiftboot and lever) from the gearbox. (picture 2).

Caution: Remove the complete assembly only when the shifter is in neutral!

Caution: Shifter / Lever will drip oil, please cover with oil absorbing material to prevent spillage.

After removing and cleaning the shifter lever assembly, remove the white plastic ring on the lever by cutting it in half and slide the large shiftboot from the lever.

Now remove the nylon cup from the bottom of the gearlever and install it on the short shifter lever.

The plastic guide on the large center ball can be pried out with a small screwdriver and installed on the short shifter (picture 3)

Now please put the white plastic ring and the black spring ring on the short-shifter lever and slide the new small shiftboot on the top part of the short shift lever.

Before installation of the shortshift lever, please remove the plastic ring from the gearbox. You can use a small screwdriver to pry the ring out. Please insert the new adapter ring from the kit with the opening over the protrusion.



Now install the washer on the adapter ring and put the plastic ring on top of that.(pic 4/5/6)



picture 4



picture 5



picture 6



I.L. MOTORSPORT

Installation Instructions

Short-Shifter for MX-5 NC – 5 gear

NC0-7000

11.2016

Lay the paper gasket on top, and install the spacer. The protrusion from the spacer should be in the same position as the protrusion in the gearbox and be seated in the cutout of the plastic ring. (picture 6)

Now install the short shifter lever perpendicular in the gearbox. You will have to put the groove on the lever over the protrusion. Install the shift boot with the supplied screws.

Secure the plastic ring with zip ties to the shift boot.
Install the large shift boot.

Install the centre console.

Tip: Check if all connectors (for example window switch) have been inserted and function properly.